

Uppgjord (även faktaansvarig om annan) - Prepared (also subject responsible if other) EAB/JM/TDU EMWPWIK		Nr - No. 1301-NGT 211 04 Uen	
Dokansv/Godk - Doc respons/Approved EAB/JM/TDU (Kajsa Lundberg)	Kontr - Checked	Datum - Date 2006-12-15	Rev G
		File	

EARTHING KIT

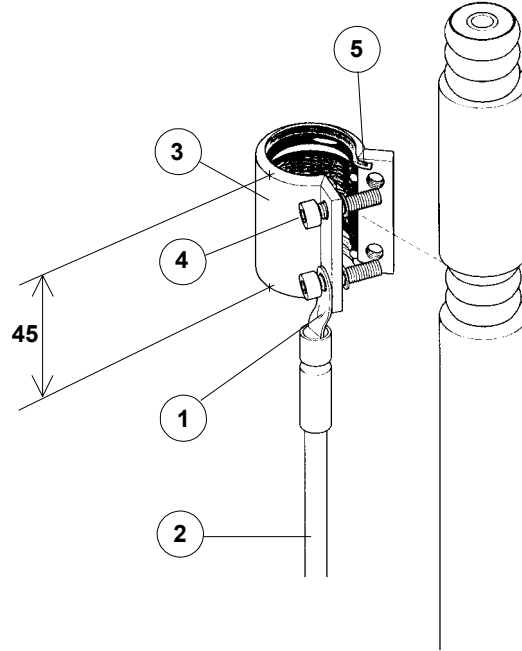

Figure 1.

Contact surface, tinned

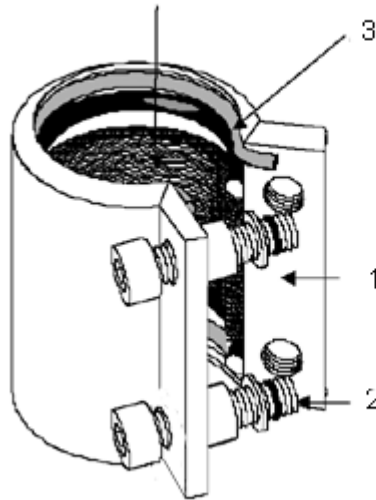

Figure 2.

Uppgjord (även faktaansvarig om annan) - Prepared (also subject responsible if other) EAB/JM/TDU EMWPWIK		Nr - No. 1301-NGT 211 04 Uen	
Dokansv/Godk - Doc respons/Approved EAB/JM/TDU (Kajsa Lundberg)	Kontr - Checked	Datum - Date 2006-12-15	Rev G File

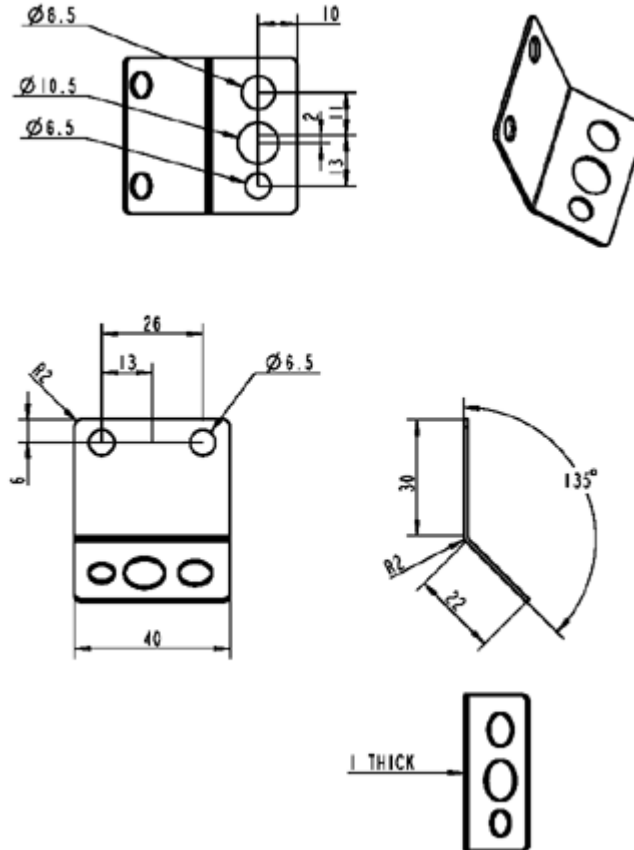

Figure 3.

1 GENERAL

1.1 DESCRIPTION

Earthing kit designed to provide proper electrical contact between the outer conductor of elliptical waveguide or coaxial cable and either a tower member or tower down conductor as a lightning path towards earth.

2 DESIGN

This specification is a simplified description of the product. The supplier has to select and specify all the parts of the product.

The earthing kit has to be designed for worldwide use in outdoor equipment with a operational lifetime of 20 years.

2.1 DIMENSIONS

Dimensions in millimetres.

Uppgjord (även faktaansvarig om annan) - Prepared (also subject responsible if other) EAB/JM/TDU EMWPWIK		Nr - No. 1301-NGT 211 04 Uen	
Dokansv/Godk - Doc respons/Approved EAB/JM/TDU (Kajsa Lundberg)	Kontr - Checked	Datum - Date 2006-12-15	Rev G File

2.2 ENVIRONMENTAL REQUIREMENTS

- Temperature range -45°C to +85°C
- IP65
- Leak proof. No leakage may occur when a waveguide or cable with the earthing kit is put under air pressure 100 kPa and put into water.

2.3 PARTS FOR EARTHING KIT NGT 211 04/1 – NGT 211 04/7

<u>Item.</u>	<u>Title</u>
1	Cable lug
2	Ground wire
3	Grounding kit body
4	Hexagon socket head cap screw M6x20, 2pcs.
5	Butyl sealing rope

2.4 PARTS FOR EARTHING KIT NGT 211 04/8

<u>Item.</u>	<u>Title</u>
1	Grounding kit body.
2	Hexagon socket head cap screw M6x20, 2pcs.
3	Butyl sealing rope
4	Mounting bracket.

3 ITEM DESCRIPTION

3.1 CABLE LUG

At the free end of the grounding wire there shall be a cable lug for M8-screw.

3.2 GROUND WIRE

The copper area of the grounding wire shall be 14 mm² minimum. The length of the grounding wire is stated in the product list.

The grounding wire shall be premounted to the grounding kit body.

3.3 GROUNDING KIT BODY

The grounding kit body accommodates necessary elements for both electrical and mechanical interfaces. The metal part of the body is made of stainless steel and rubber coated except for the zones needed for the electrical connections.

The electrical connections between the grounding kit body and the waveguide or the cable screen are achieved by a woven tin plated metal wire filling.

The sealing between the grounding kit body and the jacket of the waveguide or the coaxial cable is accomplished by a sealing compound (Butyl sealing rope).

Uppgjord (även faktaansvarig om annan) - Prepared (also subject responsible if other) EAB/JM/TDU EMWPWIK		Nr - No. 1301-NGT 211 04 Uen	
Dokansv/Godk - Doc respons/Approved EAB/JM/TDU (Kajsa Lundberg)	Kontr - Checked	Datum - Date 2006-12-15	Rev G
		File	

3.4 HEXAGON SOCKET HEAD CAP SCREW

Hexagon socket head cap screw M6x20. Stainless steel type A2-70 according to ISO 3506. Both screws shall be captive.

3.5 BUTYL SEALING ROPE

Butyl sealing ropes covered by a protective removable paper. The ropes are placed in groves located in both ends of the grounding kit body

3.6 MOUNTING BRACKET

The dimensions shall be according to figure 3 and the material shall be stainless steel type A2 according to ISO 3506.

The mounting bracket shall be premounted to the grounding kit body with its 135°-bend located at the same side as the head of the screws.

4 PRODUCT AND MANUFACTURING REQUIREMENTS

Design responsible within Ericsson shall before start of deliveries approve a sample of the earthing kit.

After approval no changes may be introduced before previous confirmation by design responsible.

5 PRODUCT QUALITY

The product shall meet the requirements in Quality specification, 105 63-2031 Uen.

6 MARKING

Each component shall be marked with the manufacturer's name and/or trademark. If limit in space on the component the marking must be on the package.

The marking on the component must be resistant to mechanical wearing and common fluids that may be used at normal handling, storage and operation.

6.1 MARKING ON NGT 211 04/6

Product and package label shall be marked with R-state according to 1095-.

7 PACKING

The package shall be marked according to the following:

1. Ericsson product number.
2. Manufacturer's name or trademark and product designation.
3. Date of manufacture, preferably year and week in a digit code according to ISO 8601 (yyyyWvv) or batch code.
4. Number of components.

Uppgjord (även faktaansvarig om annan) - Prepared (also subject responsible if other) EAB/JM/TDU EMWPWIK		Nr - No. 1301-NGT 211 04 Uen	
Dokansv/Godk - Doc respons/Approved EAB/JM/TDU (Kajsa Lundberg)	Kontr - Checked	Datum - Date 2006-12-15	Rev G
			File

8 REFERENCES

- | | |
|-----------------|--|
| 105 63-2031 Uen | General quality requirements on components |
| ISO 3506 | Stainless steels |
| ISO 8601 | Marking specification |

9 INTERNAL INFORMATION

9.1 MOUNTING

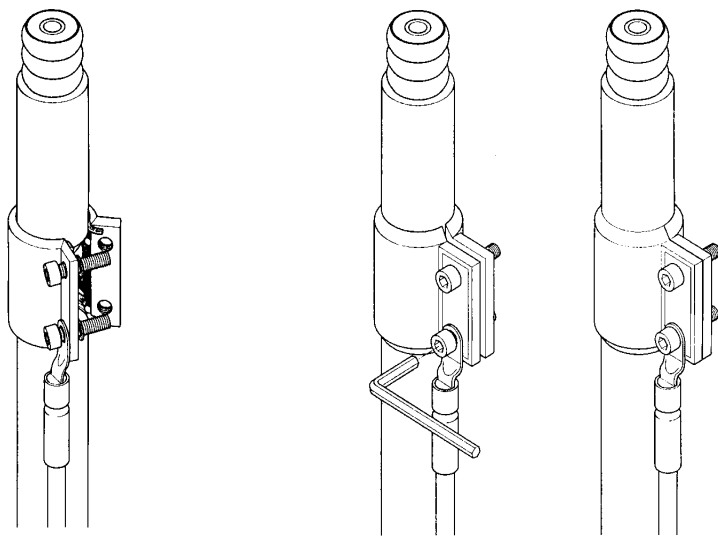

Remove covering paper from butyl sealing.
Wrap the grounding kit body round the cable and align it.

Mount the two screw's rigidly.

Uppgjord (även faktaansvarig om annan) - Prepared (also subject responsible if other) EAB/JM/TDU EMWPWIK		Nr - No. 1301-NGT 211 04 Uen	
Dokansv/Godk - Doc respons/Approved EAB/JM/TDU (Kajsa Lundberg)	Kontr - Checked	Datum - Date 2006-12-15	Rev G File

10

PRODUCT LIST

Product number	Figure	Size of Waveguide/ coaxial cable		Ground wire L mm
		mm	inch	
NGT 211 04/1	1	22.2	7/8	1000
NGT 211 04/2	1	12.7	1/2	1000
NGT 211 04/3	1	9.52	3/8	1000
NGT 211 04/4	1	31.75	1 1/4	1000
NGT 211 04/5	1	41.275	1 5/8	1000
NGT 211 04/6	1	7.2-7.6		1000
NGT 211 04/7	1	10		1000
NGT 211 04/8	2, 3	12.7	1/2	-

11

DOCUMENT REVISION INFORMATION

Revision	Description
B	Paragraph 8; Product number NGT 211 04/4 to NGT 211 04/7 added.
C	The document has been re-written.
D	Information in the header corrected.
E	Product number NGT 211 04/8, figure 2 and 3 added. Information about stainless steel grade added for screw M6x20. Item description modified.